

Surface Mount Models



Catalog #	Type	Type
Project		
Comments		Date
Prepared by		

DESCRIPTION

- Mini-electrical inverter systems for powering up to 220W/250VA of incandescent, fluorescent, induction or LED lighting loads. Pulse width modulated (PWM) output design provides clean, 60 Hz. sinusoidal emergency power to loads.
- Models are available for surface, recessed or T-Grid mounting as required.

MOUNTING

- Surface Mount (Standard Models): Surface mount models are designed for mounting to walls by means of keyhole slots provided in the back of the unit housing.
- Recess Mount (SPS-55/125, SPS-110/125 Only): Recess models provide recess mounting holes on both sides of the enclosure.
- T-Grid Mount (SPS-55/125, SPS-110/125 Only): Housing design allows simple drop-in installation between T-grid runs. Safety wires (supplied by others) are required for attachment to building structure.

DIMENSIONS

Standard Surface Mount Housings

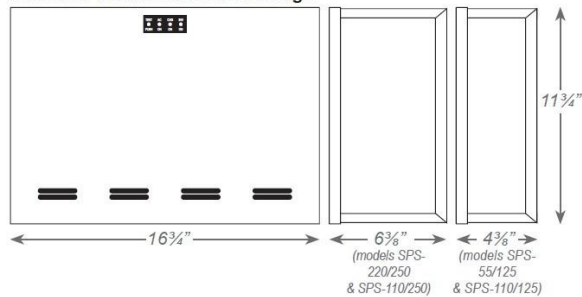

Optional Ceiling T-grid Mount Housing

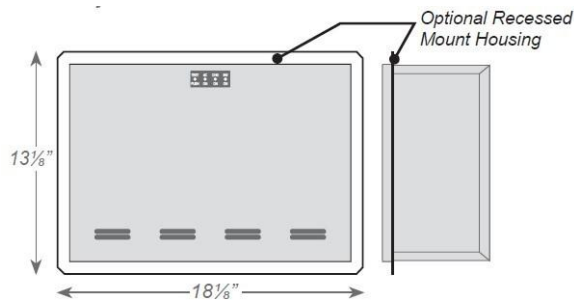
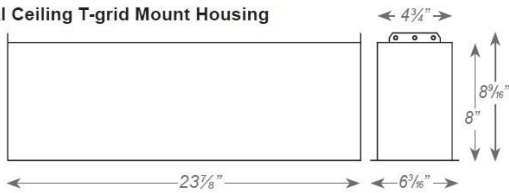

WARRANTY / LISTING

- Unit: (excluding lamps) Full coverage against defects in materials and workmanship for 3 years from date of shipment.
- Battery: 3 years full warranty plus an additional 7 years of pro-rata coverage.
- All models are UL924 Listed and meet NFPA 101 Life Safety Code, NEC, OSHA, Local and State Codes. Optional T-Grid models are plenum rated.
- UL Listed for damp locations (20° - 30°C).

ELECTRICAL SPECIFICATIONS

Input

- Input Voltages: 120 or 277VAC ±10%
- Input Frequencies: 60Hz ±2%
- Input Protection: AC Line Fuses

Output

- Output Voltages: (60Hz) 120 or 277VAC
- Efficiency Rating: 98% at full rated load (line)
- Waveform: Sinusoidal (digitally controlled)
- Static Voltage: ±5% during battery discharge. 0-100% linear load.
- Output Frequencies: 60Hz. ±0.3Hz during emergency cycle
- Output Distortion: Less than 3% THD (linear load)
- Transfer Time: Less than 1.0 second
- Load Power Factor Range: 0.44 Lead to 0.44 Lag
- Minimum Loading: 0% of rated system capacity

HOUSING

- Heavy duty steel cabinet is finished in white baked-on powder paint providing scratch and corrosion resistance.
- Optional special color paint (-SP) finishes are available, consult factory.

The SPS Series is designed to provide up to 220W/250VA of emergency power to incandescent, fluorescent, induction and/or LED fixtures. The SPS unit provides clean, sinusoidal AC output power allowing it to be remotely mounted up to 1,000 feet away from the controlled fixtures.

Unlike a ballast fluorescent emergency pack, the SPS provides power to the input side of the fixture, (including the ballast) eliminating any chance of incompatibility. The SPS Series is designed primarily for surface mounting, however, the SPS-55/125 and SPS-110/125 models provide optional housings for recessed or ceiling T-Grid mounting if required. All SPS systems will provide emergency power output for a minimum of 90-minutes.



FEATURES

- For powering incandescent, fluorescent, induction and LED fixtures *
- Sinusoidal output eliminates compatibility problems
- Universal 120/277VAC, 60Hz. input/output
- Unit capacities up to 220W/250VA
- “Soft Start” design reduces fixture inrush current
- Unit may be installed up to 1,000 feet from controlled fixture(s)
- Surface, recessed or T-Grid mount models
- Lumen output from fixture is 100% of nominal
- Unique design eliminates compatibility problems with LED drivers as well as fluorescent and induction ballasts
- Compatible with dimming ballasts
- Normally-ON and/or Normally-OFF load output
- Provisions for local switching capability - Always on during emergency conditions regardless of local switch position
- Emergency fixtures can be ON, OFF or SWITCHED
- Solid-state, line latched low voltage disconnect provides protection against battery deep discharge
- Long life, maintenance-free lead-calcium battery
- Momentary test switch
- AC-ON, Charge-ON and Inverter-ON LED indicators

LOAD COMPATIBILITY

SPS model's clean, sinusoidal AC output will operate incandescent lamps as well as all common fluorescent, induction and LED lamp types. Consult factory for compatibility with all other lamp types. Lighting loads are driven at 100% output for the entire emergency power cycle. This outstanding feature translates into greater occupant egress vision and safety.

SYSTEM OPTIONS ⁽¹⁾⁽²⁾

ADD SUFFIX	DESCRIPTION
-S	Surface Mount Housing
-R	Recess Mount Housing ⁽³⁾
-T	Plenum Rated Ceiling T-Grid Mount Housing ⁽³⁾
-SP	Special Housing Color (specify)
-4C	4 Output Circuit Switching ⁽⁴⁾
-RTS	Remote Test Switch Panel ⁽⁴⁾
-AO	Adjustable Output/Dimmer Bypass ⁽⁴⁾
-SDT	Self-Testing / Self-Diagnostics ⁽⁴⁾

WIRING

Connection to an unswitched AC circuit is required by the NEC. Wiring access is provided for by conduit knockouts in the unit housing. SPS-55/125 and SPS-110/125 models also provide knockouts in the back of the housing for rear wiring from standard electrical boxes when surface

MODEL NUMBER	INPUT / OUTPUT VOLTS	CAPACITY for 1½ Hrs.		SYSTEM WEIGHT*		ON-LINE SYSTEM EFFICIENCY (full load)	NUMBER of BATTERIES	BATTERY VOLTAGE (VDC)	BATTERY CURRENT (amps)	AC INPUT CURRENT		THERMAL OUTPUT in BTUs	
		WATTS	VA	Lbs.	Kg.					120VAC (max)	277VAC (max)	ON-LINE	EMERGENCY
IL-SPS-55/125	120/277	55	125	30.0	14	98%	2	24	3.4	1.2	0.52	9	90
IL-SPS-110/125	120/277	110	125	42.0	17	98%	2	24	5.7	1.2	0.52	9	95
IL-SPS-110/250	120/277	110	250	45.2	21	98%	4	48	3.3	2.4	1.10	18	163
IL-SPS-220/250	120/277	220	250	60.0	27	98%	4	48	5.6	2.4	1.10	18	167

* System weights shown include installed batteries

Due to continuous improvements, the information herein may be changed without notice

BATTERIES AND CHARGER

Battery: Sealed Lead Calcium (10year life) or Sealed Nickel-Cadmium (15year life)

Battery Voltage: 24VDC for SPS-55/125, SPS-110/125 models and 48VDC for SPS110/250, SPS220/250 models

Runtime: 90-minutes standard - based on battery performance at (25°C). Other runtimes available, consult factory.

Battery Protection: Low Voltage Battery Disconnect protects the battery from being severely damaged by deep discharge during prolonged power failures. DC Overload and Short Circuit Protection provided by a DC input fuse.

Charger Type: Fully automatic, temperature compensated, dual-mode charger

Power Consumption: 9W max. (All models) Recharge Duty Cycle: Meets UL924 requirements

Controls: Momentary test switch, AC-ON, Charge-ON and Inverter-ON LED indicator lights

Safety Circuitry: AC Lockout prevents battery discharge prior to initial unit power-up. Brownout Protection automatically switches the unit to emergency mode when utility voltage is significantly reduced.

Environmental

Altitude: < 10,000 feet (3,000m) above sea level without derating.

Operating Temperature Range:

Lead-Calcium Models: 20°C to 30°C

Nickel-Cadmium Models: 0°C to 50°C

NOTE: Optimum system performance between 20°C and 30°C; temperatures outside of this range will affect battery performance and life.

Relative Humidity: 95% non-condensing

OPERATION

Upon failure of the normal utility power the MPS unit is automatically turned on by a solid-state switching circuit and provides a minimum of 90-minutes of emergency power to the connected load. Lumen output will be maintained at 100% of the lamp's rating throughout the entire duration.

A solid-state low voltage disconnect circuit is used to protect the battery from being severely damaged by a deep discharge. When normal utility power is restored, the unit switches the load back to normal utility operation and the fully automatic, temperature compensated, dual mode charger begins to restore the battery; bringing it to full charge within UL924 specified parameters. A brown-out sensing circuit insures proper operation during "low line" conditions

SYSTEM STATUS MONITORING PANEL

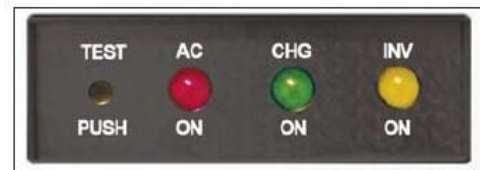

IMPROVED AESTHETICS

The MPS system's sinusoidal AC output design eliminates voltage drop and proximity concerns. This allows added flexibility in installation location as MPS units can be installed hundreds of feet from the units they power. This means MPS units to be located conveniently out of sight in closets or utility rooms without interrupting architectural aesthetics.

In lighting applications, no special or additional emergency fixtures are necessary. Simply designate and connect existing lighting fixtures, either interior or exterior, to the MPS unit for emergency operation eliminating the need for exposed, stand-alone emergency luminaires.

SPS SYSTEM ADVANTAGES

Compared to traditional discrete emergency lighting units, the SPS Series provides emergency illumination from a single power source resulting in lower maintenance overhead and routine testing expenses.

MPS units lower installation costs by powering existing lighting fixtures during emergencies. And because connected fixtures are driven at full brilliancy, they provide far superior egress lighting and deliver improved occupant safety.

SUGGESTED SPECIFICATIONS

An inverter system with sinusoidal output shall be supplied capable of powering any combination of lighting fixtures, including incandescent, fluorescent, induction and/or LED light sources without compatibility problems.

The system shall transfer in less than 1.0 second to reliably back up lighting fixtures without loss of illumination and operate any and all connected lighting fixtures at full lumen output during the complete 90-minute discharge cycle.

The input voltage shall be the same as the output voltage and shall be single phase 120/277 volts, 60 Hz. Output capacity will be (55W/125VA) / (110 Watts/125VA) / (110 Watts/250VA) / (220 Watts/250VA) for a minimum duration of 90-minutes.

The design shall be a standby, off-line inverter with on-line efficiency of 98%; on-line double conversion UPS systems shall not be considered acceptable alternatives. SPS System output shall be a PWM generated sine wave with less than 3% total harmonic distortion. The system shall also provide short circuit and overload protection as standard.

An intuitive three LED display shall provide system operational information at a glance and alert user to any malfunction in system performance. Authorized maintenance personnel shall have access to the system's controls while being protected from any live exposed connections.

Protective devices shall include AC Line fuses, DC input breaker and a DC input fuse. The entire SPS system, including batteries, shall be incorporated into compact cabinetry which shall have provisions for (surface, recessed or T-Grid) mounting.

System shall be capable of providing up to 4 switch bypass circuits, adjustable output or 0 to 10 volt dimmer bypass, remote test switch, and self-test/selfdiagnostics, were necessary

System shall utilize a sealed lead calcium battery with a 10 year design life. The charger shall be temperature compensated, dual mode type, and recharge the batteries as per UL924 guidelines. Entire system shall be tested, approved, and labeled to UL924 Emergency Lighting and Power Systems standards. T-Grid models will be plenum rated.

WIRING DIAGRAMS

277VAC Connections

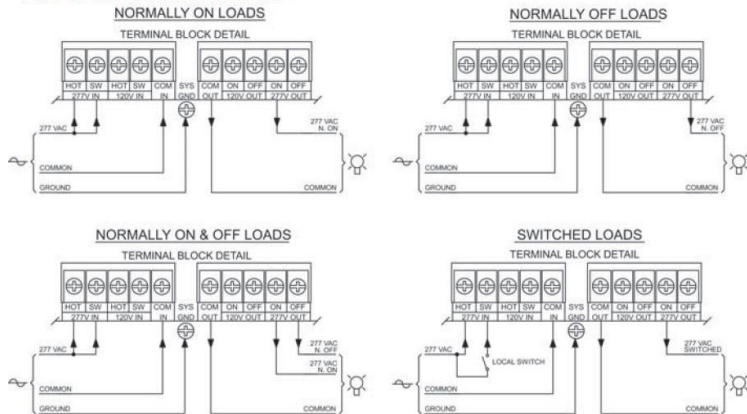

120VAC Connections

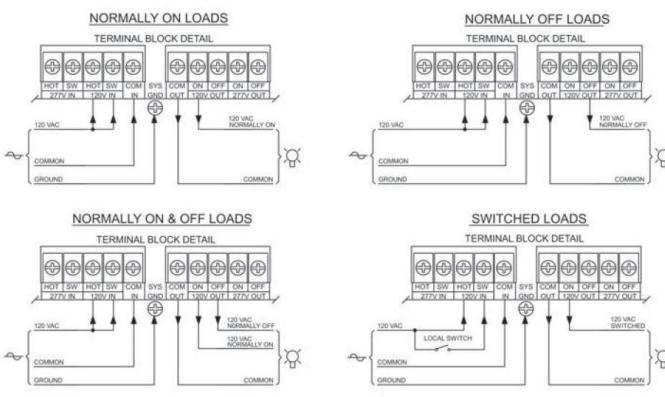

Due to continuous improvements, the information herein may be changed without notice